

DO NOT OPEN THIS TEST BOOKLET UNTIL YOU ARE TOLD TO DO SO

T.B.C. : PNGE-D-ELX

Test Booklet Series

Serial



1007213

TEST BOOKLET
PAPER II

(ELECTRONICS AND TELECOMMUNICATION ENGINEERING)

Time Allowed : Three Hours

Maximum Marks : 300

INSTRUCTIONS

1. IMMEDIATELY AFTER THE COMMENCEMENT OF THE EXAMINATION, YOU SHOULD CHECK THAT THIS TEST BOOKLET **DOES NOT** HAVE ANY UNPRINTED OR TORN OR MISSING PAGES OR ITEMS, ETC. IF SO, GET IT REPLACED BY A COMPLETE TEST BOOKLET.
2. Please note that it is the candidate's responsibility to encode and fill in the Roll Number and Test Booklet Series Code A, B, C or D carefully and without any omission or discrepancy at the appropriate places in the OMR Answer Sheet. Any omission/discrepancy will render the Answer Sheet liable for rejection.
3. You have to enter your Roll Number on the Test Booklet in the Box provided alongside.
DO NOT write *anything else* on the Test Booklet.
4. This Test Booklet contains **150** items (questions). Each item comprises four responses (answers). You will select the response which you want to mark on the Answer Sheet. In case you feel that there is more than one correct response, mark the response which you consider the best. In any case, choose **ONLY ONE** response for each item.
5. You have to mark all your responses **ONLY** on the separate Answer Sheet provided. See directions in the Answer Sheet.
6. All items carry equal marks.
7. Before you proceed to mark in the Answer Sheet the response to various items in the Test Booklet, you have to fill in some particulars in the Answer Sheet as per instructions sent to you with your Admission Certificate.
8. After you have completed filling in all your responses on the Answer Sheet and the examination has concluded, you should hand over to the Invigilator **only the Answer Sheet**. You are permitted to take away with you the Test Booklet.
9. Sheets for rough work are appended in the Test Booklet at the end.
10. **Penalty for wrong answers :**
THERE WILL BE PENALTY FOR WRONG ANSWERS MARKED BY A CANDIDATE.
 - (i) There are four alternatives for the answer to every question. For each question for which a wrong answer has been given by the candidate, **one-third** of the marks assigned to that question will be deducted as penalty.
 - (ii) If a candidate gives more than one answer, it will be treated as a **wrong answer** even if one of the given answers happens to be correct and there will be same penalty as above to that question.
 - (iii) If a question is left blank, i.e., no answer is given by the candidate, there will be **no penalty** for that question.

DO NOT OPEN THIS TEST BOOKLET UNTIL YOU ARE TOLD TO DO SO

1. A transistor with $\alpha = 0.98$ and $I_{CBO} = 5 \mu\text{A}$ is biased, so that $I_{BQ} = 100 \mu\text{A}$. What is the leakage current I_{CEO} ?

- (a) $I_{CEO} = 0.25 \text{ mA}$
 (b) $I_{CEO} = 25 \text{ mA}$
 (c) $I_{CEO} = 2.5 \text{ mA}$
 (d) $I_{CEO} = 0.25 \mu\text{A}$

2. Which one of the following is correct for the circuit shown below ?

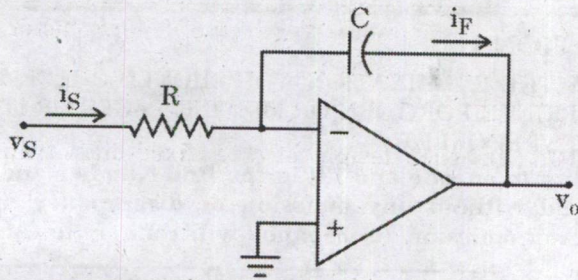

- (a) Differentiating amplifier
 (b) Integrating amplifier
 (c) First order low pass filter
 (d) Inverting amplifier

3. Consider the following statements regarding essential characteristics of a practical op-amp :

1. The open-loop voltage gain AOL is negatively infinite.
2. The input impedance between terminals 1 and 2 is infinitely large and the input current is zero.
3. The output impedance is zero and the output voltage is independent of the load.

Which of the above statements are correct ?

- (a) 1 and 2 only
 (b) 2 and 3 only
 (c) 1 and 3 only
 (d) 1, 2 and 3

4. Consider the following statements regarding common collector configuration :

1. The common-collector configuration is used primarily for impedance-matching purposes.
2. It has a high input impedance and low output impedance, opposite to that of the common-base configuration.
3. A common-collector circuit configuration is provided with the load resistor connected from emitter to ground.

Which of the above statements are correct ?

- (a) 1 and 2 only
 (b) 2 and 3 only
 (c) 1 and 3 only
 (d) 1, 2 and 3

5. I_{DSS} is the maximum drain current for a JFET and is defined by the conditions

- (a) $V_{GS} < 0 \text{ V}$ and $V_{DS} = |V_P|$
 (b) $V_{GS} = 0 \text{ V}$ and $V_{DS} > |V_P|$
 (c) $V_{GS} > 0 \text{ V}$ and $V_{DS} = 2V_P$
 (d) $V_{GS} < 0 \text{ V}$ and $V_{DS} = -V_P$

6. In which one of the following is it used that the particular operating wavelength can be selected at the time of device fabrication by an appropriate choice of the reflector spacing ?

- (a) Distributed feedback laser
 (b) Fabry-Perot laser
 (c) Tunable lasers
 (d) A vertical cavity surface emitting laser

7. Consider the following statements for an edge-emitting laser :

1. For small threshold current, Γ should be small to make the best use of the material gain.
2. A thick low band gap active region (large Γ) leads to increased losses by internal absorption α_i .
3. For large material gain, the quantum well thickness should be large.
4. Absorption losses are often caused by absorption in the high band gap outer barriers forming the waveguide.

Which of the above statements are correct ?

- (a) 1 and 4 only
- (b) 1, 2, 3 and 4
- (c) 1 and 3 only
- (d) 2 and 4 only

8. A 10 V, 50 Hz sawtooth wave is pulse width modulated by a 4 V signal. What are the outputs for high time and duty cycle respectively ?

- (a) 2 ms and 20%
- (b) 4 ms and 40%
- (c) 8 ms and 20%
- (d) 8 ms and 40%

9. Which one of the following is correct regarding channel length modulation ?

- (a) Increasing V_{DS} causes the current to increase when the length factor L is increased.
- (b) Increasing V_{DS} causes the current to decrease when the length factor L is decreased.
- (c) Increasing V_{DS} causes the current to increase when the length factor L is decreased.
- (d) Increasing V_{DS} causes the current to decrease when the length factor L is increased.

10. In the design of the fixed-bias transistor circuit shown in the figure, what are the values of R_C and R_B respectively for a Q-point of $I_C = 6 \text{ mA}$ and $V_{CE} = 4 \text{ V}$, the transistor forward current gain is $\beta_F = 200$ with a negligible β_R , $V_{BE} = 0.7 \text{ V}$?

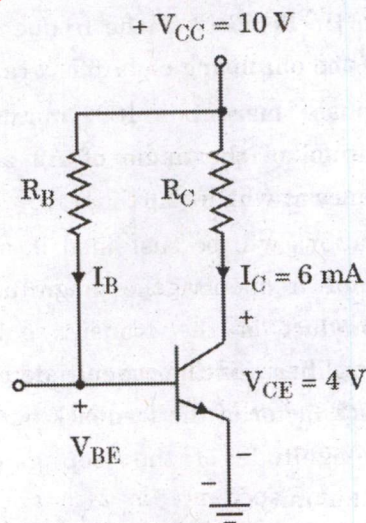

- (a) $R_C = 2 \text{ kilo ohm}$, $R_B = 610 \text{ kilo ohm}$
- (b) $R_C = 1 \text{ kilo ohm}$, $R_B = 310 \text{ kilo ohm}$
- (c) $R_C = 2 \text{ kilo ohm}$, $R_B = 310 \text{ kilo ohm}$
- (d) $R_C = 1 \text{ kilo ohm}$, $R_B = 610 \text{ kilo ohm}$

11. What is the output voltage V_o for the network given below ?

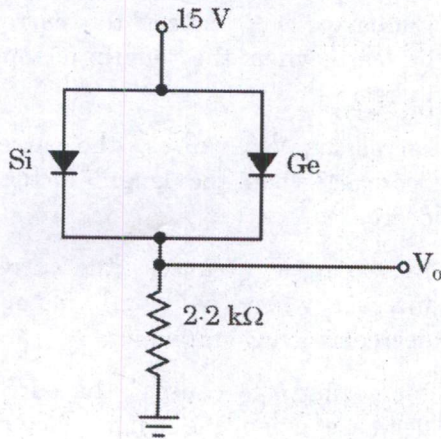

- (a) 13.3 V
 (b) 14.7 V
 (c) 15 V
 (d) 16 V

12. Consider the following statements :

- The gain margin is defined as the value of $|A\beta|$ in decibels at the frequency at which the phase angle of $A\beta$ is π radian.
- The phase margin is 180° minus the magnitude of the angle of $A\beta$ at the frequency at which $|A\beta|$ is zero.
- Oscillations will be sustained if, at the oscillator frequency, the magnitude of the product of the transfer gain of the amplifier and the magnitude of the feedback factor of the feedback network (the magnitude of the loop gain) is less than unity.

Which of the above statements are **not** correct ?

- (a) 1 and 2 only
 (b) 2 and 3 only
 (c) 1 and 3 only
 (d) 1, 2 and 3

13. Consider the following statements regarding a Gaussian process :

- If a Gaussian process is wide sense stationary, then the process is not stationary in the strict sense.
- If the Gaussian process $X(t)$ is applied to a stable linear filter, then the random process $Y(t)$ developed at the output of the filter is also Gaussian.
- If the random variables $X(t_1), X(t_2), \dots, X(t_n)$, obtained by sampling a Gaussian process $X(t)$ at times t_1, t_2, \dots, t_n are uncorrelated, then these random variables are not statistically independent.

Which of the above statements is/are correct ?

- (a) 1 and 2
 (b) 1 and 3
 (c) 1 only
 (d) 2 only

14. Consider the following statements regarding information theory :

- The information capacity of a continuous channel of bandwidth B Hertz, perturbed by additive white Gaussian noise of power spectral density $N_0/2$ and limited in bandwidth to B , is $C = B \log_2 \left(1 + \frac{P}{N_0 B} \right)$ bits per second, where P is the average transmitted power.
- The mutual information is always non-negative.
- The mutual information of a channel is symmetric.
- The mutual information of the channel is related to the joint entropy of the channel input and channel output by $I(x, y) = H(x) - H(y) + H(x, y)$.

Which of the above statements are correct ?

- (a) 1, 2 and 3 only
 (b) 2 and 3 only
 (c) 2, 3 and 4 only
 (d) 1, 2, 3 and 4

15. Consider the following statements regarding the communication system :

1. The baseband signal contains frequencies in the audio frequency range, some form of frequency-band shifting must be employed for the radio communication system to operate properly.
2. Digital repeaters reconstruct the received digital data by minimizing the effect of signal attenuation and distortion. Thus channel noise is not cumulative.
3. A digital signal can be propagated through a limited distance only, otherwise higher signal attenuation can introduce unacceptable errors.

Which of the above statements are correct ?

- (a) 1 and 2 only
- (b) 1 and 3 only
- (c) 2 and 3 only
- (d) 1, 2 and 3

16. Which one of the following mid-band frequency of IF section is used in FM radio ?

- (a) 100.7 MHz
- (b) 10.7 MHz
- (c) 0.455 MHz
- (d) 455 MHz

17. Consider the following statements :

1. DSB-SC, SSB and VSB are examples of linear modulation.
2. DSB-SC modulation is well suited for point-to-point communication.
3. SSB-SC modulation scheme is less affected by frequency selective fading.

Which of the above statements is/are correct ?

- (a) 1 only
- (b) 2 and 3 only
- (c) 1 and 3 only
- (d) 1, 2 and 3

18. Which one of the following schemes is used for transmission of the video signal in commercial television broadcasting ?

- (a) SSB
- (b) DBB
- (c) VSB
- (d) FM

19. A high resolution black and white TV picture consists of about 2×10^6 picture elements and 16 different brightness levels. Pictures are repeated at the rate of 32 per second. All picture elements are assumed to be independent and all levels have equal likelihood of occurrence. The average rate of information conveyed by this TV picture source is
- 4 Mb/s
 - 256 Mb/s
 - 64 Mb/s
 - 16 Mb/s
20. A carrier is frequency modulated with a sinusoidal signal of 2 KHz, resulting in a maximum frequency deviation of 5 KHz. The bandwidth of the modulated signal is
- 14 KHz
 - 24 KHz
 - 10 KHz
 - 48 KHz
21. If, in addition to being stationary, the random process is also ergodic in nature, then the relation between power content P_X and autocorrelation function is
- $P_X = R_X(0)$
 - $P_X \neq R_X(0)$
 - $P_X = 2R_X(0)$
 - $P_X = \frac{1}{2} R_X(0)$
22. In angle modulation, which of the following two factors limit the value of the modulation index β ?
- Channel bandwidth and received power
 - Pre-emphasis and de-emphasis
 - Received noise power and signal power
 - Pre-emphasis and received noise power
23. In which one of the following modulation schemes is the quantizer a 1-bit (two-level) quantizer with magnitudes $\pm \Delta$?
- PCM
 - DPCM
 - DM
 - ADM
24. The average probability of bit error in each channel of the coherent QPSK system is (where E and N_0 are the signal energy and noise spectral density respectively)
- $\frac{1}{2} \operatorname{erfc} \left(\sqrt{\frac{N_0}{2}} \right)$
 - $\frac{1}{2} \operatorname{erfc} \left(\sqrt{\frac{E/2}{N_0}} \right)$
 - $\frac{1}{2} \operatorname{erfc} \left(\sqrt{\frac{N_0/2}{E}} \right)$
 - $\operatorname{erfc} \left(\sqrt{\frac{E}{N_0}} \right)$

25. Consider the following drawbacks of avalanche photodiodes :

1. Fabrication difficulties due to their more complex structure and hence increased cost.
2. The random nature of the gain mechanism which gives an additional noise contribution.
3. The high bias voltages required particularly for silicon devices (150 to 400 V) which although lower for germanium and InGaAs APDs (20 to 40 V) are similarly wavelength dependent.

Which of the above drawbacks is/are correct ?

- (a) 1 and 3 only
- (b) 2 only
- (c) 2 and 3 only
- (d) 1, 2 and 3

26. The current (I_2) of the circuit given below is

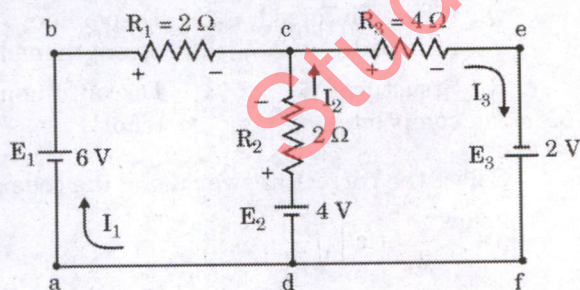

- (a) 2 mA
- (b) 20 mA
- (c) 0.2 A
- (d) 2 A

27. The lithium intercalation reaction in Lithium-ion battery is

- (a) $\text{Li}_x\text{C}_n \rightleftharpoons x\text{Li}^+ + x + \text{C}_n\text{e}^-$
→ discharge ← charge
- (b) $\text{Li}_x\text{C}_n \rightleftharpoons x\text{Li}^+ + x + \text{C}_n$
→ discharge ← charge
- (c) $\text{Li}_x\text{C}_n \rightleftharpoons x\text{Li}^+\text{e}^- + x + \text{C}_n$
→ discharge ← charge
- (d) $\text{Li}_x\text{C}_n \rightleftharpoons x\text{Li}^+ + x\text{e}^- + \text{C}_n$
→ discharge ← charge

28. The conversion efficiency of fuel cells is approximately

- (a) 50%
- (b) 60%
- (c) 70%
- (d) 80%

29. The magnetic core of a transformer is made up of stacks of thin laminations of cold-rolled grain-oriented silicon steel sheets of thickness

- (a) 0.20 mm
- (b) 0.25 mm
- (c) 0.30 mm
- (d) 0.35 mm

30. A relay which is used in oil-immersed transformers for protection against all kinds of faults, is known as

- (a) Latching relay
- (b) Reed relay
- (c) Solid state relay
- (d) Buchholz relay

31. Consider the following statements :
1. In induction machine, the field winding is placed on the stator and the armature winding on the rotor.
 2. In DC machine, the stator windings serve as both armature windings and field windings.
 3. In synchronous machine, the rotor carries the field winding and the stator carries the armature winding.

Which of the above statements is/are correct ?

- (a) 1 only
- (b) 2 only
- (c) 3 only
- (d) 1, 2 and 3

32. Consider the following statements :

1. The coordination number and the atomic packing factor for the Hexagonal Close-Packed (HCP) crystal structure are less than the Body-Centered Cubic (BCC) crystal structure.
2. The coordination number and the atomic packing factor for the Hexagonal Close-Packed (HCP) crystal structure are greater than the Face-Centered Cubic (FCC) crystal structure.
3. The coordination number and the atomic packing factor for the Hexagonal Close-Packed (HCP) crystal structure are equal to the Face-Centered Cubic (FCC) crystal structure.

Which of the above statements is/are **not** correct ?

- (a) 1 only
- (b) 1 and 2 only
- (c) 2 and 3 only
- (d) 1, 2 and 3

33. The equilibrium number of vacancies N_v for a given quantity of material

- (a) increases linearly with temperature
- (b) increases exponentially with temperature
- (c) decreases linearly with temperature
- (d) decreases exponentially with temperature

34. Silicon Carbide (SiC) has

- (a) a Rock Salt crystal structure
- (b) a Cesium Chloride crystal structure
- (c) a Zinc Blende crystal structure
- (d) a Perovskite crystal structure

35. Match the following lists :

List-I
(Composites)

List-II
(Sub classification of composites)

- | | |
|-----------------------------------|----------------------------|
| P. Particle-reinforced composites | 1. Laminates |
| Q. Fiber-reinforced composites | 2. Dispersion strengthened |
| R. Structural composites | 3. Discontinuous (short) |

Select the correct answer using the code given below :

- | | P | Q | R |
|-----|----------|----------|----------|
| (a) | 1 | 2 | 3 |
| (b) | 3 | 1 | 2 |
| (c) | 2 | 3 | 1 |
| (d) | 2 | 1 | 3 |

36. The critical fiber length of the fiber-reinforced composite ranges between

- (a) 5 and 20 times the fiber diameter
- (b) 150 and 200 times the fiber diameter
- (c) 150 and 250 times the fiber diameter
- (d) 20 and 150 times the fiber diameter

37. Match the following :

<i>List-I</i> (Material)	<i>List-II</i> (Magnetism)
P. Silicon	1. Ferromagnetism
Q. Molybdenum	2. Diamagnetism
R. Cobalt	3. Paramagnetism

Select the correct answer using the code given below :

	P	Q	R
(a)	1	2	3
(b)	2	3	1
(c)	2	1	3
(d)	3	2	1

38. The cross-correlation of two finite length sequences $x(n) = \{1, 2, 1, 1\}$ and $y(n) = \{1, 1, 2, 1\}$ is

- (a) $\{1, 2, 5, 6, 6, 4, 1\}$
- (b) $\{1, 1, 4, 6, 6, 5, 2\}$
- (c) $\{5, 2, 1, 1, 4, 6, 6\}$
- (d) $\{1, 4, 6, 6, 5, 2, 1\}$

39. Consider the following relations of continuous time unit impulse function :

- 1. $\delta(t) = \delta(-t)$
- 2. $\int_{-\infty}^{+\infty} x(t) \delta(t) dt = x(0) = 0$
- 3. $\delta(at) = \frac{1}{|a|} \delta(t)$

Which of the above relations is/are correct ?

- (a) 2 only
- (b) 1 and 2
- (c) 1 and 3
- (d) 2 and 3

40. Consider the following statements :

- 1. Impulse response $h_1(n) = 3^n u(n)$ indicates the system is non-causal system.
- 2. Impulse response $h_2(n) = \cos \frac{n\pi}{2}$ indicates the system is causal system.
- 3. Impulse response $h_3(n) = e^{-5|n|}$ indicates the system is causal system.

Which of the above statements is/are **not** correct ?

- (a) 3 only
- (b) 1 and 2
- (c) 1 and 3
- (d) 2 and 3

41. The system represented by
 $5s^6 + 8s^5 + 12s^4 + 20s^3 + 100s^2 + 150s + 200 = 0$
 is

- (a) a stable system having all poles in the right half of the s-plane.
- (b) an unstable system having one pole in the right half of the s-plane.
- (c) a stable system having one pole in the right half of the s-plane.
- (d) an unstable system having two poles in the right half of the s-plane.

42. For the unity feedback system given by
 $(s) = \frac{K}{s(s+1)(s+2)}$, the range of K for
 stability is

- (a) $0 < K < 2$
- (b) $0 < K < 3$
- (c) $0 < K < 6$
- (d) $1 < K < 6$

43. What are the breakaway points of the root locus of a unity feedback system with open loop transfer function $G(s) = \frac{K(s+2)}{(s+1)^2}$?

- (a) -1, 2
- (b) -1, 3
- (c) -1, -2
- (d) -1, -3

44. Consider the following statements regarding the Bode plot for the type-2 system having transfer function of the form :

$$G(j\omega) = \frac{K}{(j\omega)^2 (1 + j\omega T)}$$

1. The intercept of the low frequency slope of -40 dB/decade (or its extension) with the 0 dB axis occurs at a frequency ω_x , where $\omega_x = K$.
2. The value on the low frequency slope of -40 dB/decade (or its extension) at the frequency $\omega = 1$, is equal to $40 \log(K)$.
3. The gain K is the static ramp error coefficient.

Which of the above statements is/are **not** correct?

- (a) 1 only
- (b) 1 and 2
- (c) 1 and 3
- (d) 2 and 3

45. Consider the following statements :

1. Gain margin is used to indicate the proximity of the intersection of the negative real axis made by the polar plot of $G(j\omega)H(j\omega)$ to the $(-1 + j)$ point.
2. Phase crossover point is the point in the $G(j\omega)$ plane at which the polar $G(j\omega)H(j\omega)$ plot intersects the positive real axis.
3. The phase crossover frequency is the frequency at the phase crossover point or where angle $\{G(j\omega)H(j\omega)\} = 180^\circ$.

Which of the above statements is/are **not** correct?

- (a) 2 only
- (b) 1 and 2 only
- (c) 1 and 3 only
- (d) 2 and 3 only

46. If the open loop transfer function of a servo system with unity feedback is $G(s) = \frac{10}{s(1+0.1s)}$, then the acceleration, velocity and position error constants are respectively

- (a) $\infty, 0, 1$
- (b) $0, 1, \infty$
- (c) $0, 10, \infty$
- (d) $\infty, 1, 10$

47. A feedback system has an open loop transfer function of $G(s)H(s) = \frac{K(1-s)}{s(s^2+5s+9)}$. The maximum value of K for the closed loop system to be stable is

- (a) 3.5
- (b) 4.8
- (c) 6.5
- (d) 7.5

48. A unity feedback system is characterized by an open-loop transfer function $G(s) = \frac{K}{s(s+10)}$. If the damping ratio is 0.5, then the time to peak overshoot for the unit step input is

- (a) 0.125 sec
- (b) 0.175 sec
- (c) 0.254 sec
- (d) 0.363 sec

49. Consider the following statements :

1. Rise time for the underdamped system is the time required for the response to rise from 5% to 95% of its final value.
2. The amount of maximum overshoot directly indicates the relative stability of the system.
3. Settling time is the time required for the response to reach and maintain within a specified tolerance band, i.e. either 3% or 6% of the final value.

Which of the above statements are *not* correct ?

- (a) 1 and 2 only
- (b) 1 and 3 only
- (c) 2 and 3 only
- (d) 1, 2 and 3

50. Consider the following statements :

1. In PD controllers, derivative action provides the counterbalancing effect of rapidly changing disturbances, which does not take care of the offset.
2. In PI controllers, proportionality constant provides simplicity, reliability, directness, etc.
3. PI systems have some oscillatory effect.

Which of the above statements are correct ?

- (a) 1 and 2 only
- (b) 1 and 3 only
- (c) 2 and 3 only
- (d) 1, 2 and 3

51. The crystal structure of Titanium metal is
- Face-Centered Cubic
 - Body-Centered Cubic
 - Hexagonal Close-Packed
 - Having randomly organized unit cells

52. Manganese oxide (MnO) is a
- Ferrimagnetic material
 - Antiferromagnetic material
 - Ferromagnetic material
 - Paramagnetic material

53. Consider the following statements regarding measurement system :

- In the case of suspended coil permanent magnet moving coil (PMMC) instruments, the release of internal strain of the suspension wire causes drift of the zero-setting.
- Creep of a transducer is usually defined as the change of output with time following a step increase in the input from one value to another.
- Even above the threshold input, an instrument needs a minimum increment in the input to produce a perceptible output. This minimum necessary increment is called the resolution of the instrument.

Which of the above statements is/are correct ?

- 1 only
- 1 and 2 only
- 1 and 3 only
- 1, 2 and 3

54. Dead-zone in a pyrometer is 0.125% of the span. The instrument is calibrated from 800°C to 1800°C. What is the value of temperature below which no change can be detected ?

- 0.125°C
- 1°C
- 1.25°C
- 2.25°C

55. Consider the following statements regarding measurement system :

- If a known voltage of 200 V is being measured by a voltmeter and the successive readings are 204, 205, 203, 203 and 205 volts, then the accuracy is about 1.25%.
- If 'a' denotes accuracy, 'p' denotes the precision and 'c' denotes the calibration error, then $a = p + c$.
- Though the instrument is showing the correct value, the precision of the measurement depends upon the number of significant figures to which the observer can read the value.

Which of the above statements is/are *not* correct ?

- 1 only
- 2 only
- 1 and 2
- 2 and 3

56. Consider the following statements regarding wet and dry bulb Hygrometer :

1. Ubiquitous hygrometer consists of two mercury-in-glass thermometers, the bulb of one of which is covered with a wick or muslin.
2. Wick or muslin, in turn, is always kept moist by dipping both its ends into water contained in a small vessel.
3. Continuous evaporation of water from the surface of the wet bulb keeps its temperature lower than that of the dry bulb.

Which of the above statements is/are **not** correct ?

- (a) 1 only
- (b) 2 only
- (c) 1 and 2
- (d) 2 and 3

57. Consider the following statements regarding capacitive hygrometer

1. It is suitable for measuring moisture content in many gases including hydrocarbons.
2. Being a capacitor, it can be easily incorporated in microprocessor-based electronic instrumentation.
3. It cannot be used to measure moisture content in polar materials such as alcohols.

Which of the above statements is/are correct ?

- (a) 1 and 2 only
- (b) 1 and 3 only
- (c) 2 and 3 only
- (d) 1, 2 and 3

58. What is the output of a successive approximation type 8-bit ADC if the input is 491 mV and the reference is 512 mV ?

- (a) 11101011
- (b) 11110101
- (c) 11111011
- (d) 11011010

59. What is the percentage error in the measurement of kinetic energy of a body if the percentage error in the measurement of mass and speed is 2% and 3% respectively ?

- (a) 4%
- (b) 6%
- (c) 8%
- (d) 12%

60. A mass of 10 kg is measured with an instrument and the readings are normally distributed with respect to the mean of 10 kg. Given that

$$\frac{2}{\sqrt{2\pi}} \int_0^{0.84} \exp\left(-\frac{\eta^2}{2}\right) d\eta = 0.6$$

and 60 percent of the recordings are found to be within 0.05 kg from the mean. The standard deviation of the data is

- (a) 0.02
- (b) 0.06
- (c) 0.12
- (d) 0.18

61. The mean time between failures and the mean failure rate if 100 faults were recorded for 300 transducers of a system during 1.5 years, the mean down time being 1 day, are respectively
- 2.245 years and 0.123 per year
 - 4.497 years and 0.222 per year
 - 6.787 years and 0.436 per year
 - 8.525 years and 0.662 per year
62. A potentiometer is used to measure the displacement of a hydraulic ram. The potentiometer is 25 cm long, has a total resistance of 2500 ohms and is operating at 4 W with a voltage source. If it has linear resistance-displacement characteristics, then the sensitivity of the potentiometer (without loading effect) is
- 2 V/cm
 - 4 V/cm
 - 8 V/cm
 - 12 V/cm
63. Assume we have a computer where the clocks per instruction (CPI) is 1.0 when all memory accesses hit in the cache. The only data accesses are loads and stores, and these total 50% of the instructions. If the miss penalty is 25 clock cycles and the miss rate is 2%, how much faster would the computer be if all instructions were cache hits ?
- 2.75 times faster
 - 1.75 times faster
 - 3.75 times faster
 - 4.75 times faster
64. Which one of the following is **not** correct when one goes down a memory hierarchy ?
- Decreasing cost per bit
 - Increasing capacity
 - Decreasing access time
 - Decreasing frequency of access of the memory by the processor
65. Which one of the following is the disadvantage of the software pole ?
- Timing, and it can be rectified by daisy chain.
 - Delay, and it can be rectified by vectored interrupt.
 - Longest routing, and it can be rectified by multiple interrupt lines.
 - Response time, and it can be rectified by interrupt controller.
66. Which one of the following is **not** related to the CISC architecture ?
- Typically 100 – 250 instructions
 - 5 – 20 addressing modes
 - Fixed length instruction formats
 - Instructions that manipulate operands in memory

67. Which one of the following steps is **not** correct for an asynchronous data transfer ?

- (a) When the character is not being sent, the line is kept in the 0 state.
- (b) The initiation of a character of a transmission is detected from the start bit which is always zero.
- (c) The character bit always follows the start bit.
- (d) After the last bit of the character is transmitted, the stop bit is detected.

68. In deadlock condition, at least one resource must be held in a non-shareable mode; that is, only one process at a time can use the resource. If another process requests that resource, the requesting process must be delayed until the resource has been released. This is called

- (a) Circular wait
- (b) Mutual exclusion
- (c) Hold and wait
- (d) No preemption

69. Which one of the following statements is **not** correct for a buffer ?

- (a) Buffering is to cope with a speed mismatch between the producer and consumer of a data stream.
- (b) Buffering is to adapt between devices that have different data-transfer sizes.
- (c) Buffering is to support copy semantics for application I/O.
- (d) Buffering holds a copy on faster storage of an item that resides elsewhere.

70. In a program, the following declaration :

```
float number1, number2, sum, average;
```

is represented as

- (a) variables
- (b) floating numbers
- (c) input data
- (d) decimal numbers

71. Which one of the following is **not** correct about Rambus DRAM ?

- (a) The special DRAM bus delivers address and control information using an asynchronous block oriented protocol.
- (b) Data rate is 1.6 GBps.
- (c) Its operation can be controlled by the explicit RAS, CAS, R/W & CE signals.
- (d) It sends data to the controller synchronously to the clock to master, and the controller sends data to an RDRAM synchronously with the clock signal in opposite direction.

72. Non-uniform memory access belongs to

- (a) SISD
- (b) SIMD
- (c) MISD
- (d) MIMD

73. What single-precision number does the following 32-bit word represent ?

11000000101000000000000000000000

- (a) - 2
- (b) - 4
- (c) - 5
- (d) - 7

74. A better measure of memory-hierarchy performance is the average time to access memory. This can be represented as

- (a) Average memory access time =
 $\text{Hit time} + 2(\text{Miss rate} \times \text{Miss penalty})$
- (b) Average memory access time =
 $\text{Hit time} + \text{Miss rate} \times \text{Miss penalty}$
- (c) Average memory access time =
 $2 \text{ Hit time} + \text{Miss rate} \times \text{Miss penalty}$
- (d) Average memory access time =
 $\text{Hit time} + (\text{Miss rate} \times \text{Miss penalty})/2$

75. Which of the following are used to make a decision that determines the program flow, based on ALU results or the contents of register ?

- (a) BCD codes
- (b) Grey codes
- (c) Condition codes
- (d) Excess-3 codes

76. Consider the following statements regarding the LVDT :

- 1. The LVDT output is basically an amplitude modulated signal. There is a possibility of a mix-up between the modulation frequency and the carrier frequency when the displacement varies sinusoidally.
- 2. Linearity is good up to 10 mm.
- 3. Sensitivity is high, approximately 80 V/m.

Which of the above statements are *not* correct ?

- (a) 1 and 2 only
- (b) 1 and 3 only
- (c) 2 and 3 only
- (d) 1, 2 and 3

77. Consider the following statements regarding filled system thermometers :

- 1. In case of system failure, usually the entire unit needs to be replaced.
- 2. Capillary allows considerable separation between the point of measurement and the point of indication.
- 3. Complex design makes them expensive.

Which of the above statements are correct ?

- (a) 1 and 2 only
- (b) 1 and 3 only
- (c) 2 and 3 only
- (d) 1, 2 and 3

78. Consider the following statements regarding transducers :

1. Eddy-current gauge is used to measure the displacement.
2. Pirani gauge is used for high pressure.
3. Wiedemann effect is used in transducers to measure the torque, force, displacement and level measurement.

Which of the above statements are correct ?

- (a) 1 and 2 only
- (b) 1 and 3 only
- (c) 2 and 3 only
- (d) 1, 2 and 3

79. Consider the following statements regarding electromagnetic flowmeter :

1. It is not suitable for metering corrosive acids, cement slurries, detergents, greasy and sticky fluids.
2. It can measure high flow rates.
3. The liquid has to be conducting (conductivity $> 10^{-6}$ mho-cm); this requirement eliminates its use for all gases and for most of the hydrocarbons.

Which of the above statements is/are **not** correct ?

- (a) 3 only
- (b) 1 and 2
- (c) 1 and 3
- (d) 2 and 3

80. Consider the following statements regarding the vibrating element pressure transducer :

1. It generates an inherently digital signal which is amenable to its acquisition by the microprocessor-based instrumentation.
2. It is sensitive to temperature variation, shock and vibration.
3. The detectable pressure range is typically from 10 mm of Hg to 6000 psig (42 MPa) with a typical accuracy of 0.1% of the span.

Which of the above statements are correct ?

- (a) 1 and 2 only
- (b) 1 and 3 only
- (c) 2 and 3 only
- (d) 1, 2 and 3

81. For the two-port network given below, what is the transfer impedance (Z_{21}) ?

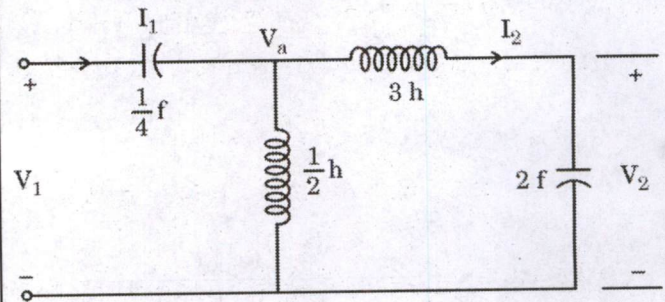

- (a) $\frac{s}{14s^2 + 3}$
- (b) $\frac{s^2}{14s^2 + 3}$
- (c) $\frac{s}{14s^2 + 2}$
- (d) $\frac{s^2}{14s^2 + 2}$

82. For the network shown below, what is the voltage $v_o(t)$ across the resistor R , the switch closes at $t = 0$, and assume all initial conditions are zero at $t = 0$?

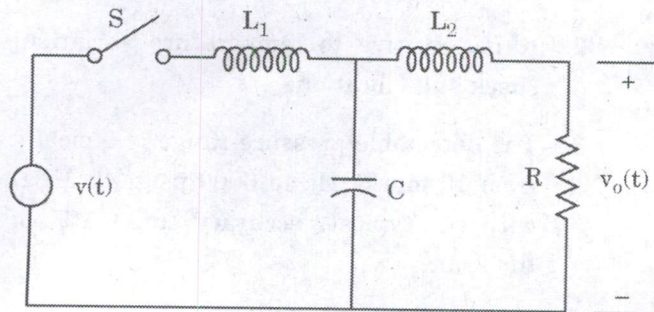

(a) $L^{-1} \left\{ \frac{RV(s) \left(\frac{1}{sC} \right)}{(R + sL_2) \left(sL_1 + \frac{1}{sC} \right) + L_1/C} \right\}$

(b) $L^{-1} \left\{ \frac{RV(s) \left(\frac{1}{sC} \right)}{(R + sL_2) \left(sL_1 + \frac{1}{sC} \right) + L_1/C} \right\}$

(c) $L^{-1} \left\{ \frac{RV(s) \left(\frac{1}{sC} \right)}{(R + sL_2) \left(sL_1 + \frac{1}{sC} \right) + L_2/C} \right\}$

(d) $L^{-1} \left\{ \frac{V(s) \left(\frac{1}{sC} \right)}{(R + sL_2) \left(sL_1 + \frac{1}{sC} \right) + L_1/C} \right\}$

83. Consider the following statements regarding the semiconductor diode :

1. PIV rating for the silicon is near about 1000 V.
2. Maximum PIV rating for the germanium is closer to 200 V.
3. Germanium can be used for applications in which the temperature may rise to about 200°C.

Which of the above statements are *not* correct ?

- (a) 1 and 2 only
- (b) 1 and 3 only
- (c) 2 and 3 only
- (d) 1, 2 and 3

84. Consider the following statements regarding the semiconductor diode :

1. Ac or dynamic resistance can be defined as $r_d = \frac{26mV}{I_d}$.
2. The lower the Q-point of operation, the lower is the ac resistance.
3. As with the dc and ac resistance levels, the lower the level of currents used to determine the average resistance, the higher is the resistance level.

Which of the above statements are correct ?

- (a) 1 and 2 only
- (b) 1 and 3 only
- (c) 2 and 3 only
- (d) 1, 2 and 3

85. Consider the following statements regarding the BJT :

1. In the dc mode, the levels of I_E and I_C due to majority carriers are related by a quantity called alpha and defined by $\alpha_{dc} = \frac{\Delta I_C}{\Delta I_E}$.
2. In the case of ac mode, alpha is formally called the common-base, forward current amplification factor.
3. For linear (least distortion) amplification purpose, cutoff for the common-emitter configuration will be defined by $I_C = I_{CEO}$.

Which of the above statements are correct ?

- (a) 1 and 2 only
 - (b) 1 and 3 only
 - (c) 2 and 3 only
 - (d) 1, 2 and 3
86. For the typical transistor amplifier in the active region, V_{CE} is usually about
- (a) 7% to 50% of V_{CC}
 - (b) 15% to 50% of V_{CC}
 - (c) 20% to 70% of V_{CC}
 - (d) 25% to 75% of V_{CC}
87. Consider the following statements regarding the BJT :
1. β decreases with decrease in temperature.
 2. $|V_{BE}|$ decreases about 2.5 mV per degree Celsius increase in temperature.
 3. Reverse saturation current doubles in value for every 20°C increase in temperature.

Which of the above statements is/are **not** correct ?

- (a) 1 only
- (b) 1 and 2
- (c) 1 and 3
- (d) 2 and 3

88. A non-uniform electric field is given by $E = y a_x + x a_y + 2y a_z$ V/m. A charge of 2 C is transferred from point A(1, 0, 3) to point B(2, 1, 3) along the straight line from point A to point B. What is the work done ?

- (a) -1 J
- (b) -2 J
- (c) -3 J
- (d) -4 J

89. The differential magnetic field at any point is proportional to the product of the current, differential length and the sine of the angle between the element and the line joining to that point. This is known as

- (a) Coulomb's law
- (b) Ampere's Circuital Law
- (c) Gauss's law
- (d) Biot-Savart's Law

90. A potential difference of 10 V is maintained across the ends of a copper wire 2 m in length. If the mean time between collisions is 2.7×10^{-14} s, then what is the drift velocity of the free electrons ?

- (a) $33.23 \times 10^{-2} \vec{a}_z$ m/s
- (b) $42.12 \times 10^{-4} \vec{a}_z$ m/s
- (c) $23.74 \times 10^{-3} \vec{a}_z$ m/s
- (d) $20.74 \times 10^{-2} \vec{a}_z$ m/s

91. In the international system of units (SI), charges Q_1 , Q_2 are expressed in Coulombs, distance R in meters, and the force in Newtons. The constant of proportionality k is
- $6 \times 10^{-7} \text{ m/F}$
 - $9 \times 10^9 \text{ m/F}$
 - $5 \times 10^8 \text{ m/F}$
 - $7 \times 10^{-9} \text{ m/F}$
92. Which one of the following does **not** indicate the space pervasiveness of electromagnetic effects ?
- The presence of current in two circuits in proximity to each other is accompanied by electrical forces on each conductor, forces which change if either current is changed.
 - A changing of the current in either of two such circuits is accompanied by an induced voltage in the other.
 - Capacitors consisting of metallic spheres or other conducting bodies suspended in vacuum or in an insulating medium may be charged and later discharged. During these processes wire-borne current flows onto one sphere and off the other.
 - The presence of electric charges on two bodies is accompanied by a mechanical force on each, forces which change if either charge is changed.
93. Which one of the following points is **not** related to Poynting's Theorem ?
- The variations in the time of a term corresponding to the sum of the energies associated to the electric and magnetic fields, and stored along the line.
 - The power dissipated along the line due to the Joule effect in the conductors and the losses in the dielectric.
 - The flux of the Poynting vector is coming out from the ends of the line, $p(d, t) - p(0, t)$.
 - This theorem is not applicable to the more general case of transmission lines with frequency-dependent parameters.
94. Which one of the following is **not** applicable to Channel guides ?
- It cannot provide confinement in the x dimension.
 - It is confinement of the light within the film plane, i.e. the y - z plane.
 - It is used in many active and passive devices of integrated optics, including lasers, modulators, switches and directional couplers.
 - It is used in the design of single-mode structures that are compatible with single-mode fiber guides.
95. What is the radiation resistance of an infinitesimal dipole whose overall length $l = \lambda/50$?
- 0.316Ω
 - 1.5Ω
 - 1.25Ω
 - 2.25Ω

96. When two antennas are near each other, some of the energy that is primarily intended for one ends up at the other. The amount does **not** depend on

- (a) radiation characteristics of each
- (b) relative separation between them
- (c) relative orientation of each
- (d) mutual coupling between them

97. Match the following lists :

<i>List-I</i>	<i>List-II</i>
P. Cavity-backed printed antennas	1. Difficult to make conformal
Q. Triplate	2. Low efficiency
R. Waveguide	3. Narrow bandwidth
S. Microstrip antennas	4. Coupling occurs inside structure

Select the correct answer using the code given below :

	P	Q	R	S
(a)	2	3	4	1
(b)	3	4	1	2
(c)	2	1	3	4
(d)	4	1	3	2

98. Which one of the following properties is **not** correct for skin depth ?

- (a) If the frequency is higher, then the skin depth is smaller.
- (b) If the permeability is larger, then the skin depth is smaller.
- (c) If the conductivity is larger, then the skin depth is smaller.
- (d) If the permeability is larger, then the skin depth is smaller.

99. A slot antenna of dual monopole feed has

- (a) 3 – 4 bands, wide bandwidth, low height, high fabrication complexity
- (b) 1 – 4 bands, narrow bandwidth, large height, low fabrication complexity
- (c) 2 – 3 bands, wide bandwidth, low height, low fabrication complexity
- (d) 1 – 2 bands, narrow bandwidth, medium height, low fabrication complexity

100. Consider the following statements regarding the antenna arrays :

1. A broadside array has its maximum radiation directed along the axis of the array.
2. An end-fire array has its maximum radiation directed along the axis of the array.
3. The resultant pattern for an array, which is known as pattern multiplication, is the product of the unit pattern and the group pattern.

Which of the above statements is/are correct ?

- (a) 1 and 2
- (b) 1 and 3
- (c) 2 and 3
- (d) 2 only

101. The capacitor in the figure given below is uncharged. The switch is moved to position 1 for 5 ms, then to position 2 and left there. What is the current (i_C) while the switch is in position 2?

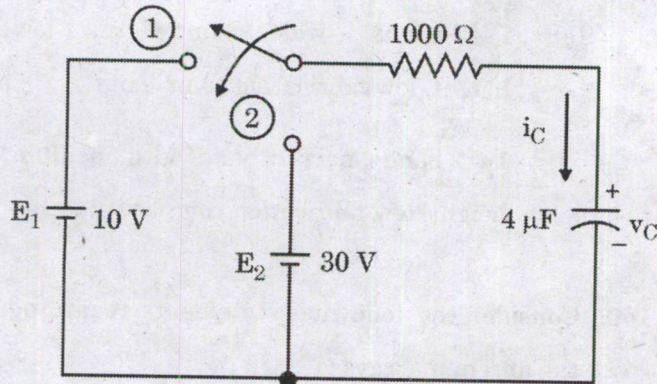

- (a) $21.86 e^{-250t}$ mA
 (b) $218 e^{-250t}$ mA
 (c) $286 e^{-250t}$ mA
 (d) $22.86 e^{-250t}$ mA

102. Which one of the following digital logic families has the worst noise immunity and power dissipation among all the digital logic families?

- (a) TTL
 (b) ECL
 (c) RTL
 (d) DTL

103. The quiescent point (Q-point) of the BJT is selected in such a way that the gain of the BJT is

- (a) increased exponentially with input signal
 (b) decreased with input signal
 (c) increased with input signal
 (d) fairly constant

104. What are the stability factor $S(V_{BE})$ and the change in collector current I_C , respectively, from 25°C to 100°C for the emitter-bias transistor configuration with $R_B = 240 \text{ k}\Omega$, $R_E = 1 \text{ k}\Omega$ and $\beta = 100$? (Take the change in voltage V_{BE} due to change in temperature to be -0.17 V)

- (a) -0.417×10^{-3} , $70.9 \mu\text{A}$
 (b) -0.417×10^{-3} , $50 \mu\text{A}$
 (c) -0.293×10^{-3} , $50 \mu\text{A}$
 (d) -0.293×10^{-3} , $70.9 \mu\text{A}$

105. An amplifier without any feedback has midband gain of -1000 , lower 3 dB frequency $f_1 = 5 \text{ kHz}$ and upper 3 dB frequency $f_2 = 50 \text{ kHz}$. If a voltage series negative feedback with feedback factor of -0.1 is used in the amplifier, then the lower and upper 3 dB frequencies of the resultant amplifier are respectively

- (a) 4.94 Hz and 5.05 kHz
 (b) 5.05 MHz and 49.50 MHz
 (c) 49.50 kHz and 49.50 MHz
 (d) 49.50 Hz and 5.05 MHz

106. What are the input and output impedances respectively with feedback for current series feedback having $A = -200$, $R_i = 15 \text{ k}\Omega$, $R_o = 25 \text{ k}\Omega$ for feedback factor of -0.25 ?

- (a) $0.76 \text{ k}\Omega$ and $1.27 \text{ k}\Omega$
- (b) $0.76 \text{ M}\Omega$ and $1.27 \text{ M}\Omega$
- (c) 765Ω and 1275Ω
- (d) $7.65 \text{ M}\Omega$ and $12.75 \text{ M}\Omega$

107. Consider the following statements :

1. In the gated S-R latch, for the $S = R = 0$, the latch output does not change.
2. In J-K flip-flop, during the interval $J = 1$, $K = 0$ and $E = 0$, flip-flop will be reset.
3. Latches and flip-flops both are basically the bistable elements.

Which of the above statements are correct?

- (a) 1 and 2 only
- (b) 1 and 3 only
- (c) 1, 2 and 3
- (d) 2 and 3 only

108. In a 4-bit serial in serial out (shift right mode) shift register using D flip-flops (negative edge triggered) all the flip-flops initially are in reset condition, i.e. $Q_3Q_2Q_1Q_0 = 0000$. The number of negative edges required to store the binary bit 1110 are

- (a) 2
- (b) 3
- (c) 4
- (d) 5

109. Function $f(a, b, c) = ab + \bar{b}c$ is implemented using 4:1 multiplexer. If a and b are considered as select lines and 'c' as an input to multiplexer, then what are the values of D_0, D_1, D_2, D_3 ?

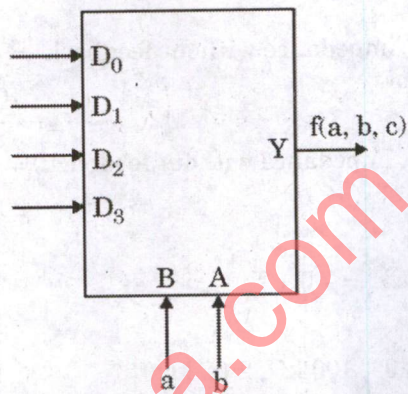

- (a) $D_0 = 1, D_1 = c, D_2 = 0, D_3 = c$
- (b) $D_0 = 1, D_1 = 1, D_2 = \bar{c}, D_3 = c$
- (c) $D_0 = c, D_1 = 1, D_2 = c, D_3 = 1$
- (d) $D_0 = c, D_1 = 0, D_2 = c, D_3 = 1$

110. Consider the following statements regarding the BJT and FET :

1. BJT is a voltage-controlled device and FET is a current-controlled device.
2. In both BJT and FET, the output current is the controlled variable.
3. Due to high input characteristics of FETs, the ac equivalent model is somewhat complex than that employed for the BJTs.

Which of the above statements is/are *not* correct?

- (a) 1 only
- (b) 1 and 2
- (c) 1 and 3
- (d) 2 and 3

111. What are the values of voltage gain, input and output impedances respectively with voltage series feedback having

$$A \text{ (gain without feedback)} = -100,$$

$$R_i \text{ (input impedance without feedback)} = 10 \text{ k}\Omega,$$

$$R_o \text{ (output impedance without feedback)} = 20 \text{ k}\Omega,$$

$$\beta \text{ (feedback)} = -0.1 ?$$

- (a) $-3.03, 100 \text{ k}\Omega, 2.02 \text{ k}\Omega$
- (b) $-9.09, 100 \text{ k}\Omega, 2.02 \text{ k}\Omega$
- (c) $-3.03, 110 \text{ k}\Omega, 1.82 \text{ k}\Omega$
- (d) $-9.09, 110 \text{ k}\Omega, 1.82 \text{ k}\Omega$

112. The frequency of practical FET Colpitts oscillator can be found by

$$(a) f_0 = \frac{1}{2\pi\sqrt{R_1 C_1 R_2 C_2}}$$

$$(b) f_0 = \frac{1}{2\pi C L_{eq}}$$

$$(c) f_0 = \frac{1}{2\pi\sqrt{R C_{eq}}}$$

$$(d) f_0 = \frac{1}{2\pi\sqrt{L C_{eq}}}$$

113. Consider the following statements :

1. Smoke test is a non-exhaustive test to ensure that the crucial requirements for the product are functioning.
2. Sanity testing is superficial testing performed to test the durability of the product.
3. Scalability test is used to test the performance aspects of the product after integration.

Which of the above statements are *not* correct ?

- (a) 1 and 2 only
- (b) 1 and 3 only
- (c) 2 and 3 only
- (d) 1, 2 and 3

114. Consider the following statements regarding the VLSI design :

1. Parallelism and pipelining have been effective ways to reduce power consumption.
2. Replacing a single functional unit with an N-stage pipelined unit reduces the amount of logic in a clock cycle at the expense of more registers.
3. When leakage is unimportant, parallelism offers a slight edge because the multiplexer has less overhead than the pipeline registers.

Which of the above statements are correct ?

- (a) 1 and 2 only
- (b) 2 and 3 only
- (c) 1 and 3 only
- (d) 1, 2 and 3

115. Consider the following statements :

1. The general formula for the minimum possible sampling rate for a bandpass signal can be recovered from the samples

$$f_s = \frac{2f_h}{\text{Largest integer not exceeding } \frac{f_h}{f_h - f_l}}$$

2. If we sample at a rate higher than twice the highest frequency, the aliases do not overlap and the original signal can be recovered.
3. The absolute minimum sampling rate in most favourable situation is twice the highest frequency, not the bandwidth of the signal.

Which of the above statements are correct ?

- (a) 1 and 2 only
- (b) 1 and 3 only
- (c) 2 and 3 only
- (d) 1, 2 and 3

116. The recursive system described by a linear constant-coefficient difference equation is

- (a) linear and time invariant
- (b) linear and time variant
- (c) non-linear and time invariant
- (d) non-linear and time variant

117. What is the input signal $x(n)$ that will generate the output $y(n) = \{1, 5, 10, 11, 8\}$ for a system with impulse response $h(n) = \{1, 2, 1\}$?

- (a) $\{1, 2, 1\}$
- (b) $\{3, 3, 1\}$
- (c) $\{1, 3, 3\}$
- (d) $\{1, 3, 1\}$

118. The convolution sum is used to give the response of

- (a) linear systems only
- (b) time invariant systems only
- (c) linear time invariant systems
- (d) causal systems only

119. If $x(n)$ is a periodic signal with fundamental period N and takes infinite values, then it is

- (a) an energy signal only
- (b) a power signal only
- (c) neither energy signal nor power signal
- (d) both energy and power signals

120. What is the particular solution of the difference equation

$$y(n) = \frac{5}{6} y(n-1) - \frac{1}{6} y(n-2) + x(n),$$

when the forcing function $x(n) = 2^n$, $n \geq 0$ and zero elsewhere ?

- (a) $y_p(n) = (-8)2^n$, $n \geq 0$
- (b) $y_p(n) = (192/5)2^n$, $n \geq 0$
- (c) $y_p(n) = (8/5)2^n$, $n \geq 0$
- (d) $y_p(n) = (-8/5)2^n$, $n \geq 0$

121. If in an n-bit carry skip adder divided into M blocks, each block is containing P adder cells, then, the total (worst case) propagation delay time is given by (k_1 denotes the time needed by the carry signal to propagate through the adder cell, k_2 denotes the time needed for a carry to skip over a block)

- (a) $2(P - 1) k_1 + (M - 2) k_2$
- (b) $2(M - 1) k_1 + (P - 2) k_2$
- (c) $(P - 1) k_2 + (M - 2) k_1$
- (d) $(P - 1) k_1 + 2(M - 2) k_2$

122. In MOS transistor, the depletion region width d for the junction is (ϵ_{si} = relative permittivity of silicon, ϵ_0 = permittivity of free space, V = effective voltage across the junction, q = electron charge, N = doping level of substrate)

- (a) $d = \sqrt{\frac{2\epsilon_{si}\epsilon_0 V}{qN}}$
- (b) $d = \sqrt{\frac{2\epsilon_{si}\epsilon_0}{qNV}}$
- (c) $d = \sqrt{\frac{\epsilon_{si}\epsilon_0 V}{qN}}$
- (d) $d = \sqrt{\frac{\epsilon_{si}\epsilon_0 V}{2qN}}$

123. Consider the following statements regarding the instruction pipelining :

1. It is used for increasing the efficiency of the advanced microprocessors.
2. Pipelining a processor means breaking down its instruction into a series of discrete pipeline stages which can be completed in sequence by specialized hardware.
3. The performance and programming simplification is achieved by pipelining operation with the elimination of pipeline interlocks and the control of pipeline is simplified.

Which of the above statements are correct ?

- (a) 1 and 2 only
- (b) 1 and 3 only
- (c) 2 and 3 only
- (d) 1, 2 and 3

124. Sample $x(t)$ at the rate of 10 samples per second. What is the ROC of its z-transform directly from $x(n)$, if the input signal $x(t) = [-2e^{-3t} + 3e^{-4t}]u(t)$?

- (a) $Z = 0.7408$
- (b) $Z = 0.6703$
- (c) $|Z| > 0.6703$
- (d) $|Z| > 0.7408$

125. Matched-z transformation method is used to design

- (a) Inverse Chebyshev filter
- (b) Non-recursive filters
- (c) All pole filters
- (d) Recursive filters

126. How many m-bit data words can be stored using an n-input, m-output programmable read only memory ?

- (a) $\frac{2^n}{n}$
- (b) $n \times 2^n$
- (c) 2^n
- (d) 2^{n-1}

127. How many numbers of unique states are possible in twisted ring counter with 5 flip flops ?

- (a) 32
- (b) 5
- (c) 10
- (d) 16

128. Essential prime implicants of the given K-map are

	AB			
CD	00	01	11	10
00	0	4	12	8
01	1	5	13	9
11	3	7	15	11
10	2	6	14	10

- (a) $\bar{A}\bar{B}C, \bar{A}\bar{B}\bar{D}, \bar{A}\bar{B}C$
- (b) $\bar{A}\bar{B}C, \bar{A}\bar{B}\bar{D}, BD, \bar{A}\bar{B}C, \bar{A}CD, \bar{B}C\bar{D}$
- (c) $\bar{A}\bar{B}C, \bar{A}CD, \bar{B}C\bar{D}$
- (d) $\bar{A}\bar{B}C, \bar{A}\bar{B}\bar{D}, BD$

129. A 12-stage counter is operating a 12-stage ladder network using a reference voltage of 10 V. If a clock rate of 1 MHz is operating a 12-stage counter, then the maximum conversion time (approximately) is

- (a) 1.20 ms
- (b) 4.10 ms
- (c) 12.10 ms
- (d) 24.40 ms

130. Minimized function of the Boolean function
 $f(A, B, C, D) = \sum M(2, 3, 4, 5, 7, 8, 10, 13, 15)$
 is

- (a) $\bar{A}\bar{B}C + \bar{A}B\bar{C} + BD + A\bar{B}\bar{D}$
- (b) $\bar{A}\bar{B}C + \bar{A}B\bar{C}\bar{D} + AC + A\bar{B}\bar{D}$
- (c) $\bar{B}C\bar{D} + \bar{A}\bar{B}C + \bar{A}B\bar{C} + BD + A\bar{B}\bar{D}$
- (d) $\bar{A}\bar{B}C\bar{D} + \bar{A}B\bar{C}\bar{D} + AC + A\bar{B}\bar{D}$

131. IC 74157 is a

- (a) 2-bit two-input multiplexer
- (b) 4-bit two-input multiplexer
- (c) 8-bit two-input multiplexer
- (d) 4-bit four-input multiplexer

132. When implementing $F(A, B, C) = AB + \bar{B}C$ with 4:1 multiplexer, the correct input sequence of multiplexer's input D_0, D_1, D_2 and D_3 are respectively

- (a) C, 1, C, 0
- (b) 0, 1, \bar{A} , A
- (c) C, 0, C, 1
- (d) 1, 0, \bar{A} , \bar{A}

133. IC 74273 is for

- (a) a positive-edge triggered D flip-flop with clear inputs
- (b) a negative-edge triggered D flip-flop with clear inputs
- (c) a pulse-triggered JK flip-flop with preset and clear inputs
- (d) a negative-edge triggered JK flip-flop with preset and clear inputs

134. Consider the following statements regarding the sequential circuit :

1. The Moore model sequential circuit is called transition-assigned circuit.
2. In the Mealy model sequential circuit, the output is associated with the state transitions, that is, the arcs in the state diagram.
3. In the Moore model sequential circuit, outputs are the functions of both, the inputs and the present state.

Which of the above statements are *not* correct ?

- (a) 1 and 2 only
- (b) 1 and 3 only
- (c) 2 and 3 only
- (d) 1, 2 and 3

135. Consider the following statement regarding the Programmable Array Logic (PAL) :

1. A PAL comprises programmable AND and OR array.
2. Unlike a PROM, in which all 2^n possible products of n variables are generated, a PAL generates only a limited number of product terms, leaving it to the designer to select those products to be generated for each sum.
3. The overall cost of a PAL is considerably lower than that of comparable PROMs and FPLAs.

Which of the above statements are correct ?

- (a) 1 and 2 only
- (b) 1 and 3 only
- (c) 2 and 3 only
- (d) 1, 2 and 3

136. Which one of the following adders divides the full adder into groups and employs carry bypass logic to speed up the carry propagation ?

- (a) Pseudo parallel adder
- (b) Carry look-ahead adder
- (c) Ripple carry adder
- (d) Binary parallel adder

137. Number of flip-flops needed to design a twisted-ring counter (SN7400 series), that has ten unique states, is

- (a) 5
- (b) 2
- (c) 10
- (d) 4

138. Match the following lists :

<i>List-I</i>	<i>List-II</i>
P. Format control	1. MAF, ETB
Q. Transmission control	2. RS, US
R. Information separator	3. EM, DC1, DC2, DC3, DC4
S. Miscellaneous	4. FF, VT

Select the correct answer using the code given below :

	P	Q	R	S
(a)	2	1	3	4
(b)	4	3	1	2
(c)	3	1	4	2
(d)	4	1	2	3

139. Common error control techniques are *not* based on

- (a) error detection
- (b) positive acknowledgement and retransmission
- (c) retransmission after time out
- (d) negative acknowledgement

140. Match the following lists :

<i>List-I</i>	<i>List-II</i>
P. SCMA	1. Interleavers are used as the only means for user separation
Q. MC-CDMA	2. Applies a new set of spreading codes that exhibit interference free window to separate users in the wireless channel
R. IDMA	3. Enables two or more users, associated with the same base station, to use the same time and frequency and code resources on the grounds of their physical location or spatial separation
S. LAS-CDMA	4. Spreads each user symbol in the frequency domain

Select the correct answer using the code given below :

	P	Q	R	S
(a)	2	4	3	1
(b)	3	4	1	2
(c)	1	2	4	3
(d)	4	3	2	1

141. Which one of the following is *not* the property of WiseMAC ?

- (a) The preamble duration is determined by the potential clock drift since last synchronization.
- (b) It uses additional contents of ACK packets.
- (c) Preamble T_P is $\min(L_0, 4T_W)$.
- (d) The packets in WiseMAC also contain a "more" bit.

142. A cell-site transmitter generates + 15 dBm RF signal and is connected to an antenna using an RF coaxial cable that induces a 3 dB loss. The cable has two connectors at its either end that induce a loss of 2 dB each. What is the signal level at the input of the antenna ?

- (a) + 5 dBm
- (b) + 6 dBm
- (c) + 7 dBm
- (d) + 8 dBm

143. Which one of the following is *not* the property of flooding ?

- (a) An effective routing approach when the information in the routing tables is not available.
- (b) It may easily swamp the network as one packet creates multiple packets that in turn create multiples of multiple packets, generating an exponential growth rate.
- (c) TTL is used to reduce the resource consumption in the network.
- (d) It requires the network to provide multiple paths for each source – destination pair.

144. Which one of the following is a disadvantage of CDMA ?

- (a) It is simple to operate.
- (b) It does not require any transmission synchronization between stations. The only synchronization required is that of the receiver to the sequence of the received carrier.
- (c) It offers sufficient protection against interference from other stations and due to multiple paths.
- (d) It has low throughput.

145. Which one of the following statements is correct for ST connector ?

- (a) It uses a ceramic ferrule and a rugged metal housing. It is latched in place by twisting.
- (b) It has a shockproof plastic housing with a retractable shroud to protect the ceramic ferrules from damage.
- (c) It is designed for multimode data communication applications and it is used for instrumentation connections.
- (d) It allows high-density connections between network equipment in telecommunication rooms.

146. Network and switching subsystem does **not** have which one of the following switches and databases ?

- (a) Mobile services switching center
- (b) Home location register
- (c) Visitor location register
- (d) Operation and maintenance center

147. Which one of the following statements is **not** correct about the D-channel contention-resolution algorithm ?

- (a) When a subscriber device has an LAPD frame to transmit, it transmits a series of binary ones on the D-channel using the pseudoternary encoding scheme.
- (b) The NT, on receipt of a D-channel bit, reflects back the binary value as a D-channel echo bit.
- (c) When a terminal is ready to transmit an LAPD frame, it listens to the stream of incoming D-channel echo bits.
- (d) To overcome collision, a transmitting TE monitors the E bits and compares them to its transmitted D bits. If a discrepancy is detected, the terminal ceases to transmit and returns to a listen state.

148. Which one of the following is **not** an advantage of a WLAN ?

- (a) Only wireless ad-hoc networks allow for communication without previous planning.
- (b) Several Government and non-Government institutions worldwide regulate the operation and restrict frequencies to minimize interference.
- (c) Wireless networks allow for the design of small, independent devices.
- (d) Wireless networks are robust.

149. Consider the following statements :

1. The VLSI circuit (all the devices and their interconnections) is fabricated on a die. In a single wafer, there are always two dies. The complete one VLSI circuit is equally distributed (fabricated) on each die.
2. Modern technologies use a diamond saw to separate the dies from the wafer.
3. A suitable compound material is used to package the die to provide protection to the die from environmental damage, to prevent the interface to the outside world, to provide the cooling of heat generated due to power dissipation.

Which of the above statements is/are correct ?

- (a) 1 and 2
- (b) 2 and 3
- (c) 2 only
- (d) 3 only

150. Consider the following statements :

1. Programmable Logic Array (PLA) is a programmable logic device with AND array followed by the OR array, where the AND array is programmable but the OR array is fixed.
2. Additional input in PLA does not require doubling the size of AND and OR array. Therefore, PLA is cheaper than Programmable Array Logic (PAL).
3. PLA is more flexible as compared to PAL and Read Only Memory (ROM).
4. PLA, PAL and ROM can be used to implement sum of product (SOP) with any number of terms.

Which of the above statements are *not* correct ?

- (a) 1, 2, 3 and 4
- (b) 1 and 2 only
- (c) 3 and 4 only
- (d) 1, 2 and 4 only

SPACE FOR ROUGH WORK

downloaded from
StudentSuvidha.com

SPACE FOR ROUGH WORK

downloaded from
StudentSuvidha.com

SPACE FOR ROUGH WORK

downloaded from
StudentSuvidha.com

SPACE FOR ROUGH WORK

downloaded from
StudentSuvidha.com